

## Assembly instructions

For a process reliable and correct pre-assembly and final-assembly



## Important notes on VOSS assembly instructions

In order to ensure maximum performance and functional reliability of VOSS products, the respective assembly instructions, operating conditions and tube recommendations have to be adhered to.

We recommend that you use VOSS pre-assembly devices at all times. The use of pre-assembly devices is a strict requirement from tube sizes L18/S16 and larger! It is absolutely essential to follow the operating instructions for the respective pre-assembly device used.

Do not start with assembly until you are absolutely sure that you have understood the operating and assembly instructions for each VOSS pre-assembly device or machine, tool and product. Incorrect handling leads to risks regarding safety and leak-tightness and can result in failure of the entire connection.

It is impossible for the manufacturer to monitor whether the user is adhering to the operating and assembly instructions for individual pre-assembly devices or machines, tools and products, as well as what conditions prevail and what methods are used for installation, operation, application and maintenance of the individual products. Improper workmanship can lead to material damage, which in turn may pose a danger to life and limb. This means that VOSS Fluid GmbH can accept no responsibility or liability for loss, damage or costs incurred due to faulty installation, improper operation or incorrect application and maintenance or from any related issue. Failure to heed this warning will lead to loss of guarantee.

VOSS Fluid GmbH reserves the right to make changes or additions to the information provided without prior notification. Customers can obtain the latest version of the operating and assembly instructions upon request, or from our download area at: [www.voss.net](http://www.voss.net)

## General notes on VOSS assembly instructions

Make sure that all components, including the tubes, are clean before assembly is started and that they remain clean during the entire assembly process. Soiled components may lead to failure of the system.

Before starting assembly, make sure that you have carried out all preparatory work in accordance with the respective instructions.

### Specifications concerning permissible steel tubes:

seamless, cold-drawn and normalized precision steel tubes as specified in DIN EN 10305-4, material E235+N, mat. no. 1.0308+N or E355, mat. no. 1.0580. The tubes must be ordered by specifying the outer diameter and the inner diameter.

### Specifications concerning permissible stainless steel tubes:

seamless, cold-drawn and solution-annealed, scale-free stainless steel tubes in CFA or CFD delivery condition of dimensions and tolerances according to DIN EN 10305-1 and all other delivery conditions as specified in DIN EN 10216-5, material X6CrNiMoTi17-12-2, mat. no. 1.4571. The tubes must be ordered by specifying the outer diameter and the inner diameter.

The tubes should be prepared with the same thoroughness as pre-assembly and final assembly of the connection. Especially when using long tubes, check the end sections for damage or distortion.

We recommend that pre-assembled tubes which are not to be finally assembled yet should be fitted with protective caps.

Marking a stroke on the union nut and the tube makes it easier to achieve the correct number of turns when tightening the coupling.

Before starting to assemble VOSS components with elastomer seals, always check that:

- the nut and the seal surfaces are clean and undamaged and/or
- the elastomer sealing is clean and undamaged

## Determining the tightening torque for screw couplings

The tightening torques specified in the catalogue apply under the following conditions:

- steel fittings with VOSS coat surface coating
- the specified nominal pressure ranges assume that the mating material has a tensile strength of  $\geq 600 \text{ N/mm}^2$
- our recommendations on lubrication of the threaded studs are observed

If other values for strength, modulus of elasticity and friction-surface combinations are used, the user has to adapt the tightening torque empirically.

The recommended tightening torques have to be adhered to if the pressure range is to be fully utilized and the appropriate safety level is to be maintained.

The recommended tightening torques for the threads are given in the tables for the respective type of thread.

## Explanation of symbols and other notes



Visual inspection



Turn until hand-tight or carry out another manual activity



Use the tool to tighten the coupling according to the instructions



Oil and lubricate at the point marked with an arrow

All dimensions in millimetres [mm]

## Assembly instructions for flange couplings / ZAKO

### 1

#### Note

Before starting the assembly work, read and observe the general notes in the up-to-date VOSS catalogue and check that your assembly instructions are up to date.

The ZAKO flange coupling product range is designed for use in pipelines with outer diameters ranging from 16 mm to 114.3 mm. Flanges with a SAE hole pattern and square flanges can be used.

Different pre-assembly devices are available for the ZAKO ring assembly, depending on the tube and pipe dimensions. In each case, the descriptions given in the relevant individual operating instructions apply to the assembly procedures.

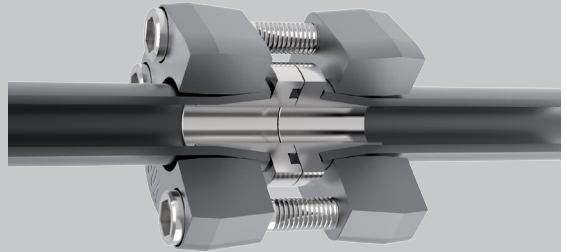

### 2

#### Tube preparation

##### 2.1 Tube lengths for connecting flanges:

The first step in determining the required tube length is to calculate the theoretical total tube length L1. After this, the length L3 must be subtracted from the total tube length for each connection used (see table for length L3).

Tube OD [mm]	Connecting flange L3 approx. [mm]	Tube OD [mm]	Coupling flange L3 approx. [mm]	L2 approx. [mm]
<b>ZAKO</b>		<b>ZAKO</b>		
16	8	16	8	5.5
20	8	20	8	5.5
25	8.5	25	8.5	5.5
30	8.5	30	8.5	6
38/42	9	38	9	7
50	10	50	10	7
60	15	60	15	12
65	11	65	11	8
75	16	75	16	12
80	16	80	16	13
88	20	88	20	16
101.6	20	101.6	20	16
114.3	20	114.3	20	16

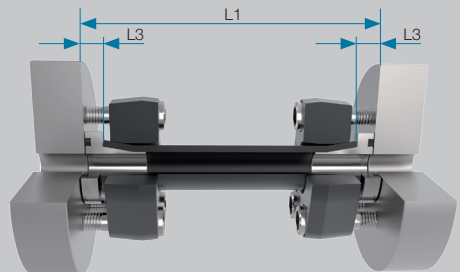

# ZAKO

## 2.2 Tube lengths for coupling flanges:

To determine the tube lengths of coupling flanges the tube lengths L3 applies to the connecting surface of the ZAKO ring with O-ring. If the connecting surface of the ZAKO ring without O-ring is required, length L2 must be taken into account.

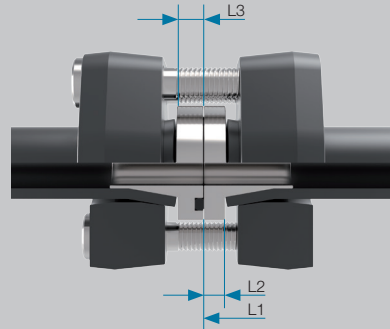

## 2.3 Compliance with straight tube length:

To assembly the ZAKO rings, a minimum tube length (L) of the straight tube end must be taken into account with curved tubing. Please observe the specifications listed here.

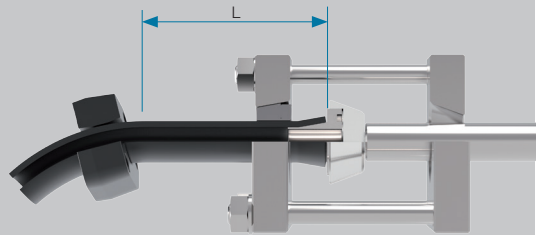

## 2.4 Preparing the tube ends:

Cut tubes at right angles. An angle tolerance of  $\pm 1^\circ$  is permissible.

Do not use tube cutters or angle grinders to cut tubes.

Deburr the inner and outer edges of the tube ends. For the couplings to fulfil their function optimally, it is recommended that the outer edges of the tube ends be deburred only slightly and the inner edges more extensively.

The tube ends must be undamaged both internally and externally and free of metal chips, dirt, rust and other contamination.

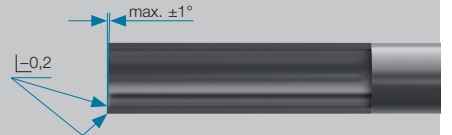

# 3

## Principle of the ZAKO ring pre-assembly

3.1 Push the ZAKO flange onto the tube with the toothed conical section of the hole pointing towards the tube end.

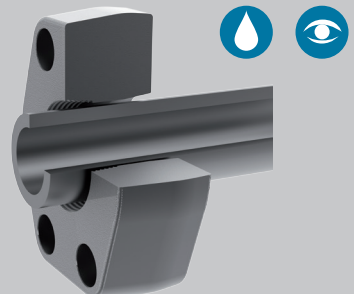

## ZAKO

### 3.2 Pre-assembly principle

The pre-assembly procedure shown here is carried out using the VOSS pre-assembly device. Pre-assembly involves pressing the ZAKO ring into the tube.

#### Attention!

Set up the pre-assembly device and tools as described in the corresponding operating instructions. The tube's outer diameter and wall thickness must be taken into account when choosing what tools to use.

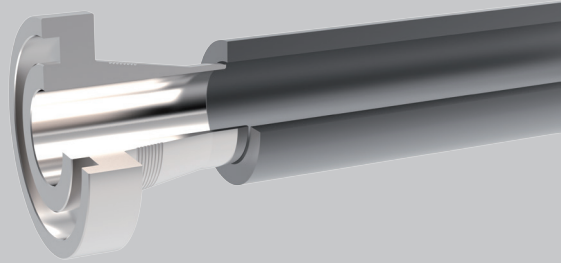

Pre-assemble the coupling as described in the operating instructions.

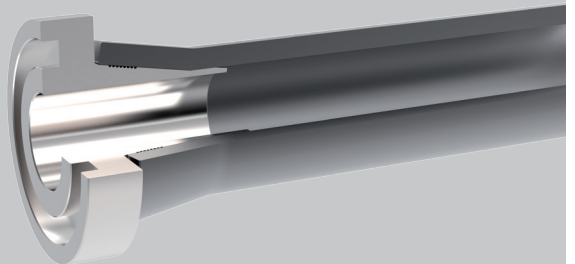

**3.3** To reduce the assembly forces, lubricate the conical and cylindrical sections of the ZAKO ring generously (e.g. using mineral-oil based hydraulic fluid HLP32).

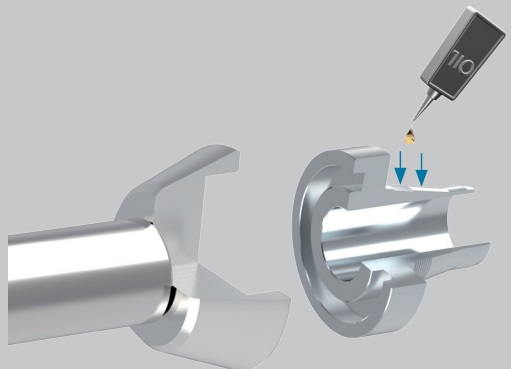

# ZAKO

**3.4** Push the tube through the opening of the yoke plate of the pre-assembly device and, while doing so, press the ZAKO ring against the pressure plate. Now clamp the clamping jaws around the tube. Push the clamping jaws along the tube until they are in the conical opening of the yoke plate.

The ZAKO ring must remain outside the assembly section of the tube.

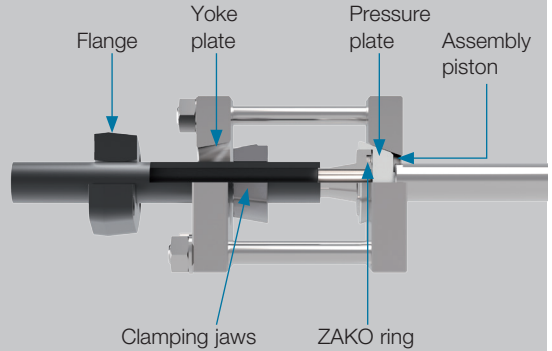

**3.5** Start the assembly process as described in the pre-assembly device operating instructions. The piston stroke pushes the ZAKO ring into the tube until the remaining gap is between  $\geq 1$  mm and 5 mm wide (see table).

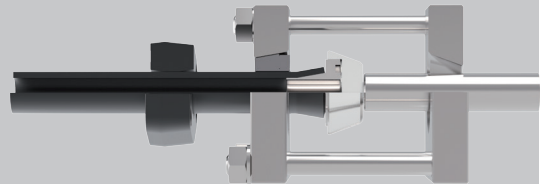

### Attention!

During the pre-assembly process the tube end must not come into contact with the ZAKO ring. The remaining gap must adhere to the specified widths.

Tube wall thickness	Gap width
< 8 mm	$\geq 1$ to 1.5 mm
8 mm < 16 mm	max. 3 mm
16 mm	max. 5 mm

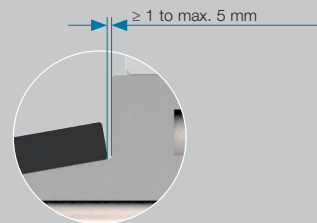

## 4

### Final assembly of the flange connection



**4.1** Clean the seal groove of the ZAKO ring and place the O-ring carefully into the groove, making sure it is not twisted.

**4.2** Lubricate the threads of the screws. (e.g. using mineral-oil based hydraulic fluid HLP32).

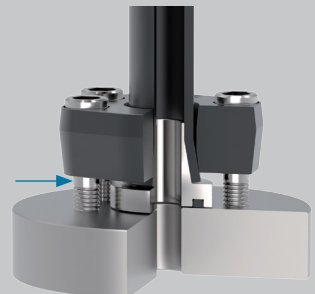

## ZAKO

**4.3** Press the pre-assembled flange connection onto the surface to which it is to be bolted and screw it on hand-tight. The tube must be stress-free and at right angles to the screw on surface.

**4.4** Then carefully tighten the securing screws diagonally and evenly in several steps using a wrench. The flange must be parallel to the connection surface. Should the deviation from parallel during checking (measure at all three points A, B and C) be greater than 0.5 mm, a correction must be made with reassembly.

**Attention!**

Do not use pneumatic wrenches.

**4.5** The final assembly is concluded by alternately tightening up the diagonally opposed pairs of the 4 screws.

**Attention!**

Do not exceed the allowed tightening torques specified for the screws (see table).

In the course of final assembly, the collar ring may be pulled towards the tube end. It is possible that the gap will then be closed (see item 3.4).

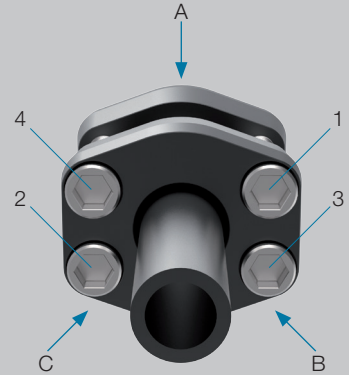

Dimension [mm]	Screw tightening torque: 10.9 [Nm max.]*
<b>ZAKO</b>	
M 8	35
M 10	69
M 12	120
M 14	190
M 16	295
M 20	580
M 24	800
M 30	1.500

\* Nm = recommended final tightening torque for cylindrical screws M 8 – M 30 for a total coefficient of friction of 0.14.



## ZAKO

### 5

#### Final assembly of the flange coupling

Note that one of the collar rings used must be a collar ring without a seal groove.

**5.1** Clean the seal groove of the ZAKO ring and place the O-ring carefully into the groove, making sure it is not twisted.

**5.2** Lubricate the threads of the screws (e.g. using mineral-oil based hydraulic fluid HLP32).

**5.3** Align the tube ends with the pre-assembled rings, fit them together and screw in the connecting screws by hand. The tubes must be perfectly aligned and must not be under tension.

**5.4** Then tighten up the screws manually, alternating diagonally opposed pairs, in several stages. Ensure that the flanges are parallel to one another. Correct the screw tension if measurements (to be taken at all three points A, B and C) show a deviation of more than 1 mm from the parallel.

#### **Attention!**

Do not use pneumatic wrenches.

**5.5** The final assembly is concluded by alternately tightening up the diagonally opposed pairs of the four screws.

#### **Attention!**

Do not exceed the allowed tightening torques specified for the screws (see table).

In the course of final assembly, the ZAKO ring may be pulled against the tube end. It is possible that the gap will be closed (see item 3.4).

**5.6** The same notes also apply to the ZAKO flange couplings for SAE hose connections (see illustration).

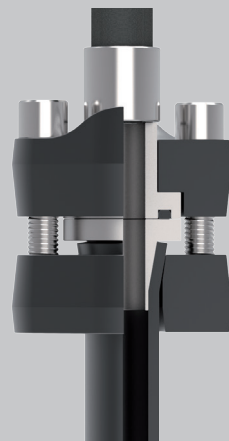
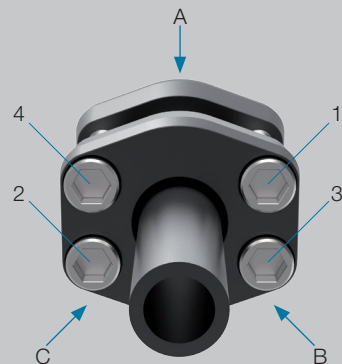
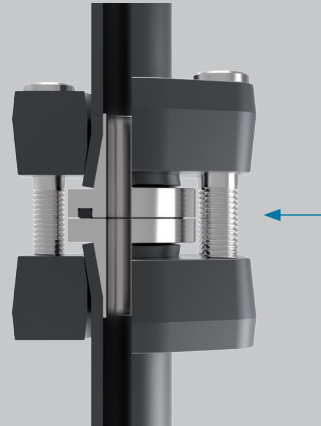

## ZAKO

6

### Re-assembly

Clean the seal groove of the ZAKO ring, inspect the condition of the O-ring and then put it back into the groove carefully, making sure it is not twisted.

ZAKO flanges are easy to re-assemble. Follow all the final assembly instruction steps when re-assembling a flange connection or coupling.



7

### Notes on subsequent inspections

Should setting make it necessary to retighten the screws, the flange plate can be pulled up to 1mm before the ZAKO ring while taking the parallel.

